

295  
 ÖLANSCHLUSS  
 FÜR ROHRLEITUNG

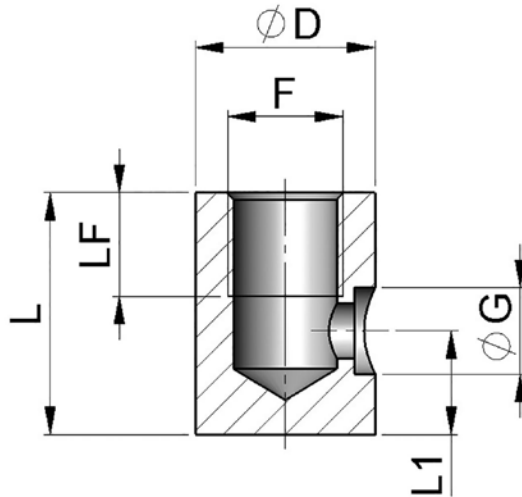

Bestellnummer	F / BSP	LF	L	øD	øG	L1	kg x 100
295 102 030 010	1/4"	15	30	22	10,5	12	6,90
295 103 035 012	3/8"	15	35	26	12,5	15	10,50
295 104 035 015	1/2"	15	35	30	15,5	15	13,20
295 M16 030 010	M16x1,5	14	30	22	10,5	11	
295 M18 035 012	M18x1,5	16	35	26	12,5	12	
295 M22 035 015	M22x1,5	18	35	30	15,5	13	
295 106 025	1"	25				45	16,90
295 107 024	1"1/4	24,5				55	22,60
295 108 030	1"1/2	30				60	28,90
295 109 030	2"	30				70	30,70

MATERIAL: STAHL 355J2C

295  
 ÖLANSCHLUSSBLOCK

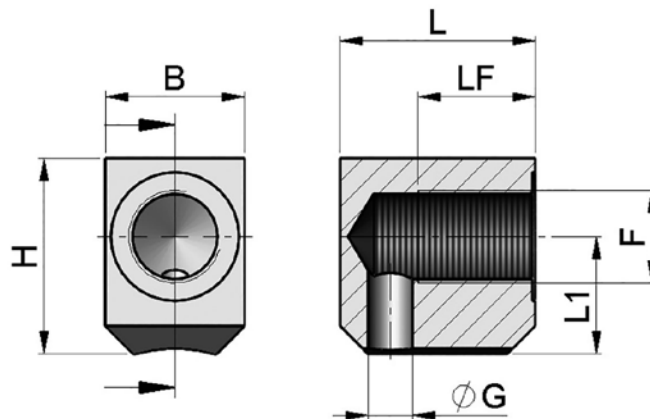
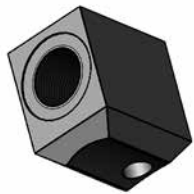

Bestellnummer	F / BSP	LF	B	L	H	øG	L1	kg x 100
295 090 102 001	1/4"	20	25	32	30	6	19	0,152
295 090 103 001	3/8"	21	25	35	35	8	21	0,178
295 090 104 001	1/2"	28	35	43	40	10	25	0,351
295 090 105 001	3/4"	25	35	50	45	12	25	0,42

MATERIAL: STAHL 355J2C